

KBH ST350 Seed Tender



- 350 Cubic Feet for 240-Bushel Capacity
- Wireless Remote Control for One-man Operation
- Hydraulic Height Adjustable Unload Conveyor
- 180 degree Pivoting Conveyor (transports front or rear)

The
KBH
CLARKSDALE ★ MS
Corporation

Featuring the patented KSI Cleated Belt

8" Belt in 6" Tube

The cleated Belt/KBH Variable Speed Power Unit gently elevates peanuts at low belt speeds or grain seeds at high belt speeds (or anything in between) with minimal rollback.

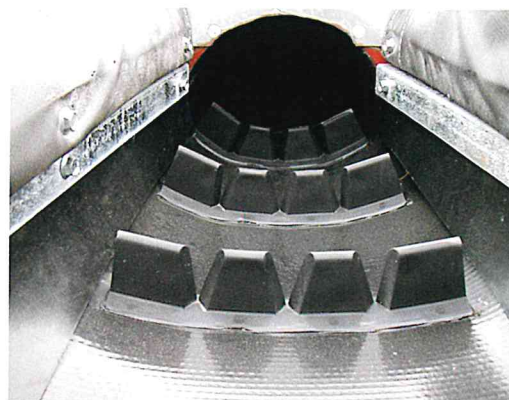

Patent No. US 6, 170, 646 & 6,675, 958

(800) 843-5241
www.kbhequipment.com

P.O. Box 670 • 395 Anderson Boulevard • Clarksdale, MS 38614

KBH ST350 Seed Tender

KBH Variable Speed All-Hydraulic Drive Power System

- Honda Electric Start Engines
GX160 for 16' belt
GX240 for 18' belt (optional)
- Direct Mount Hydraulic Pump
- Hydraulic Motor Direct Mounted to Belt Drive Shaft
- Flow Control Valve for Variable Speed Operation
- 10 Gallon Oil Reservoir with Filter
- Wireless Remote Operation (Solenoid Switch with 12V Battery)
- Years of proven, efficient use on other KBH seed Products

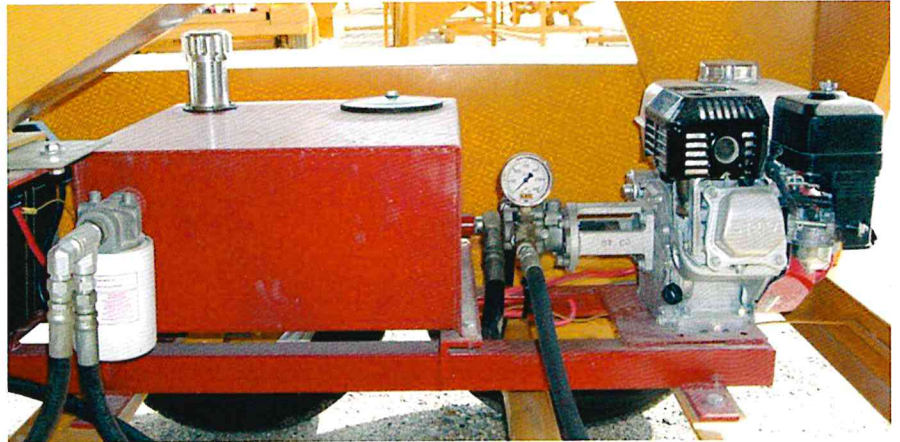

Trailer

- Tandem Rubber Torsion Axles (20,000 lb. Capacity)
- 2 .5" Spindles/8 Bolt Hubs
- 12.5 x 15FI Tires
- Fenders
- Recessed LED Trailer Lights
- 2 - 5/16" Ball or Clevis Hitch
- Retractable Tongue Jack
- Optional Electric Brakes - 13" Drums on all Four Hubs

Hopper

- 350 Cubic Feet Capacity
- Two Compartment
- 35 Degree Hopper Slope
- Sight Windows
- Roll Trap
- Ladder

Forklift Bag Handler

- Additional Horizontal and Vertical Reach



Optional Weigh Scale System

- Avery Weigh-Tronix model 640
- four weigh bars

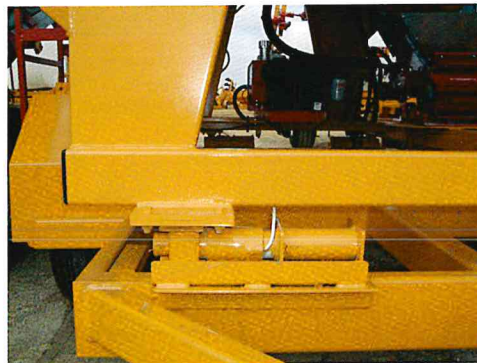

Dimensions Shown:
A. Standard 16' Belt
B. Optional 18' Belt

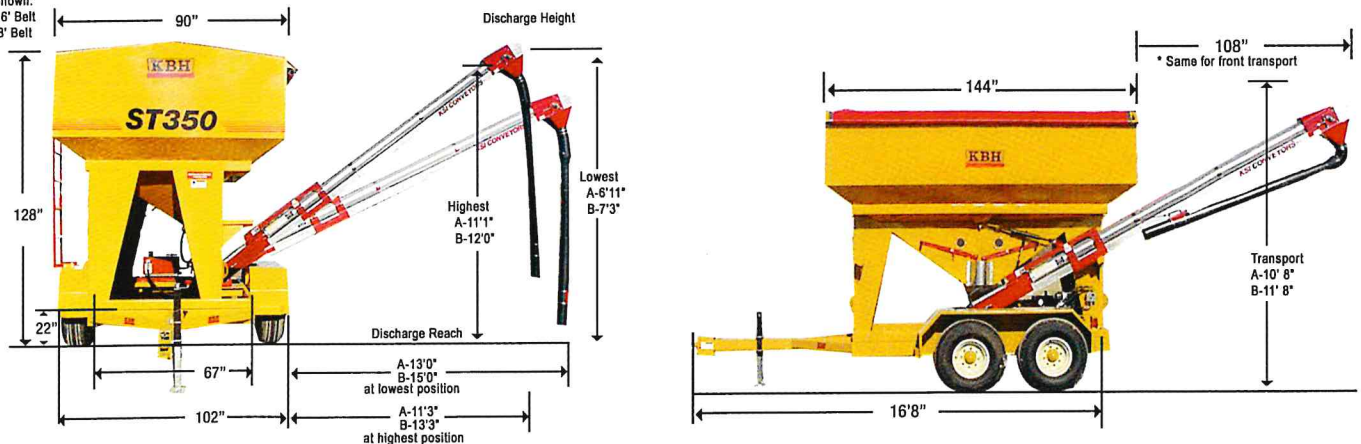

(800) 843-5241
www.kbhequipment.com